

# FLUID COOLING | Shell & Tube B Series

## COPPER & STEEL CONSTRUCTION

### Features

- Young Touchstone Interchange (Thermal)
- Optional Non-Ferrous Construction
- Competitively Priced
- 1/4" or 3/8" Tubes Standard
- Water to Water Applications
- Sea Water Applications
- Optional 90/10 Copper Nickel Cooling Tubes and Bronze End Bonnets for Sea Water Service
- NPT, SAE O-Ring, SAE Flange, or BSPP Shell Side Connections Available
- End Bonnets Removable for Servicing
- Mounting Feet Included (May be Rotated in 90° Increments)

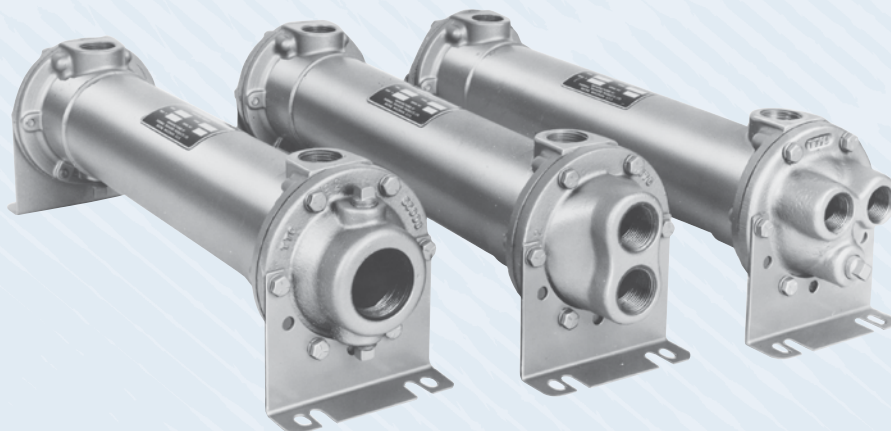

WATER COOLED B

### Ratings

- Maximum Shell Pressure** 250 psi
- Maximum Tube Side Pressure** 150 psi
- Maximum Temperature** 350° F

### Materials

- Tubes** Copper
- Hubs & Tubesheets** Steel or Brass
- Shell** Steel or Brass
- Baffles** Brass
- End Bonnets** Cast Iron
- Mounting Brackets** Steel
- Gaskets** Nitrile Rubber/Cellulose Fiber
- Nameplate** Aluminum Foil

## How to Order

<b>Model Series</b>	<b>Model Size Selected</b>	<b>Baffle Spacing</b>	<b>Tube Diameter Code</b>	<b>Tube Side Passes</b>	<b>Shell Material</b>	<b>Cooling Tube Material</b>	<b>End Bonnet Material</b>	<b>Zinc Anodes</b>	
SB SBF B BS BM BF BFM		A - 1.125 B - 2.25 C - 4.5 D - 9.0	4 - 1/4" 6 - 3/8"	O - One Pass T - Two Pass F - Four Pass	Blank - Steel BR - Brass	Blank - Copper CN - CuNi	Blank - Cast Iron B - Bronze	Blank - None Z - Zinc	

**ADD FOR B SERIES MODELS ONLY:**  
**BR-CN-B-Z** is to be used for all seawater/dirty water applications.

#### Steel Hub

- SB** = NPT Shell Side, NPT Tube Side
- SBF** = SAE Flange (with UNC threads) Shell Side connections; NPT Tube Side connections

#### Brass Hub

- B** = NPT Shell Side connections; NPT Tube Side connections
  - BS** = SAE O-Ring Shell Side connections; NPT Tube Side connections
  - BM** = BSPP Shell Side connections; BSPP Tube Side connections
  - BF** = SAE Flange (with UNC threads) Shell Side connections; NPT Tube Side connections
  - BFM** = SAE Flange (with Metric threads) Shell Side connections; BSPP Tube Side connections
- SAE flanges available on some models. Consult factory for details.

# Dimensions

## One Pass

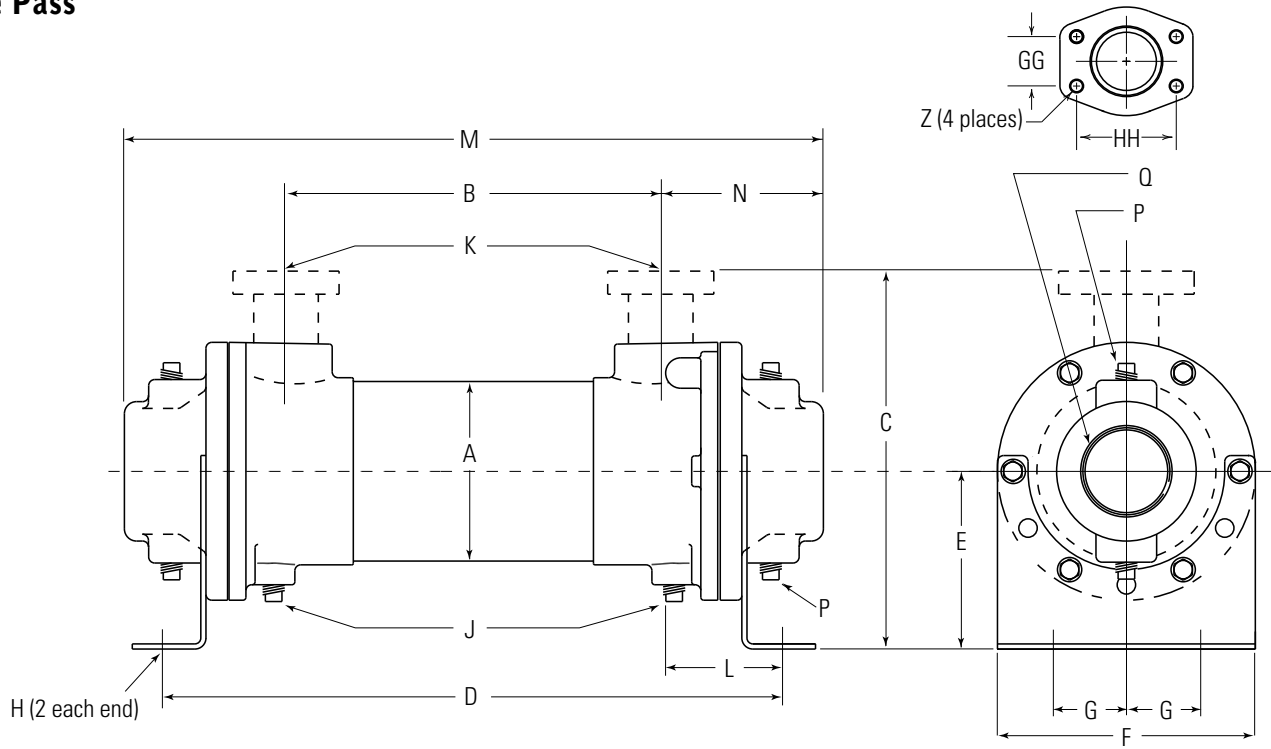

Flange Size	GG	HH	Z - CF	Z - CFM
1	1.03	2.06	3/8-16 UNC	M-10
1.50	1.41	2.75	1/2-13 UNC	M-12
2	1.69	3.06		
3	2.44	4.19	5/8-11 UNC	M-16

MODEL	A	B	C		D	E	F	G	H	J	K		L	M	N	P	Q
			NPT/BSPP SAE O-RING	SAE FLANGE							NPT/BSPP FLANGE	SAE O-RING					
B-401	2.125	7.62	3.50	—	11.01	1.94	2.62	.88	.41 Dia.	—	*.50	#8, 3/4-16 UNF-2B	1.72	11.24	1.81	—	1.00
B-402		16.62			20.01									20.24			
B-701	3.656	7.00	6.25	C/F	12.01	3.62	5.25	1.50	.44 x 1.00	(2) .38	1.00	#16, 1 <sup>3</sup> / <sub>16</sub> -12 UNF-2B	2.69	13.64	3.24	(4) .38	1.50
B-702		16.00			21.01									22.64			
B-703	5.125	25.00	7.38	8.46	30.01	4.00	6.75	2.00	.44 x 1.00	(6) .38	1.50	#24, 1 <sup>7</sup> / <sub>8</sub> -12 UN-2B	3.06	31.64	4.05	(4) .38	2.00
B-1002		15.50			21.71									23.60			
B-1003	6.125	24.50	8.81	10.50	30.71	4.75	7.50	2.50	.44 x .88	(6) .38	2.00	#32, 2 <sup>1</sup> / <sub>2</sub> -12 UN-2B	3.44	32.60	4.88	(4) .50	3.00
B-1004		33.50			39.71									41.60			
B-1202	8.00	14.62	12.13	15.61	21.50	6.50	8.62	3.50	.44 x 1.00	(6) .38	3.00	—	4.39	24.38	6.52	(4) .50	4.00
B-1203		23.50			30.38									33.25			
B-1204	8.00	32.38	12.13	15.61	39.25	6.50	8.62	3.50	.44 x 1.00	(6) .38	3.00	—	4.39	42.12	6.52	(4) .50	4.00
B-1205		41.38			48.25									51.12			
B-1206	8.00	50.50	12.13	15.61	57.38	6.50	8.62	3.50	.44 x 1.00	(6) .38	3.00	—	4.39	60.25	6.52	(4) .50	4.00
B-1207		59.50			66.38									69.25			
B-1208	8.00	68.38	12.13	15.61	75.25	6.50	8.62	3.50	.44 x 1.00	(6) .38	3.00	—	4.39	78.12	6.52	(4) .50	4.00
B-1602		13.60			22.38									26.62			
B-1603	8.00	22.60	12.13	15.61	31.38	6.50	8.62	3.50	.44 x 1.00	(6) .38	3.00	—	4.39	35.62	6.52	(4) .50	4.00
B-1604		31.60			40.38									44.62			
B-1605	8.00	40.60	12.13	15.61	49.38	6.50	8.62	3.50	.44 x 1.00	(6) .38	3.00	—	4.39	53.62	6.52	(4) .50	4.00
B-1606		49.60			58.38									62.62			
B-1607	8.00	58.60	12.13	15.61	67.38	6.50	8.62	3.50	.44 x 1.00	(6) .38	3.00	—	4.39	71.62	6.52	(4) .50	4.00
B-1608		67.60			76.38									80.62			
B-1609	8.00	76.60	12.13	15.61	85.38	6.50	8.62	3.50	.44 x 1.00	(6) .38	3.00	—	4.39	89.62	6.52	(4) .50	4.00
B-1610		85.60			94.38									98.62			

B-401 and B-402 SAE Flange not available. NOTE: We reserve the right to make reasonable design changes without notice. Consult factory. All dimensions are inches.

# Dimensions

## Two Pass

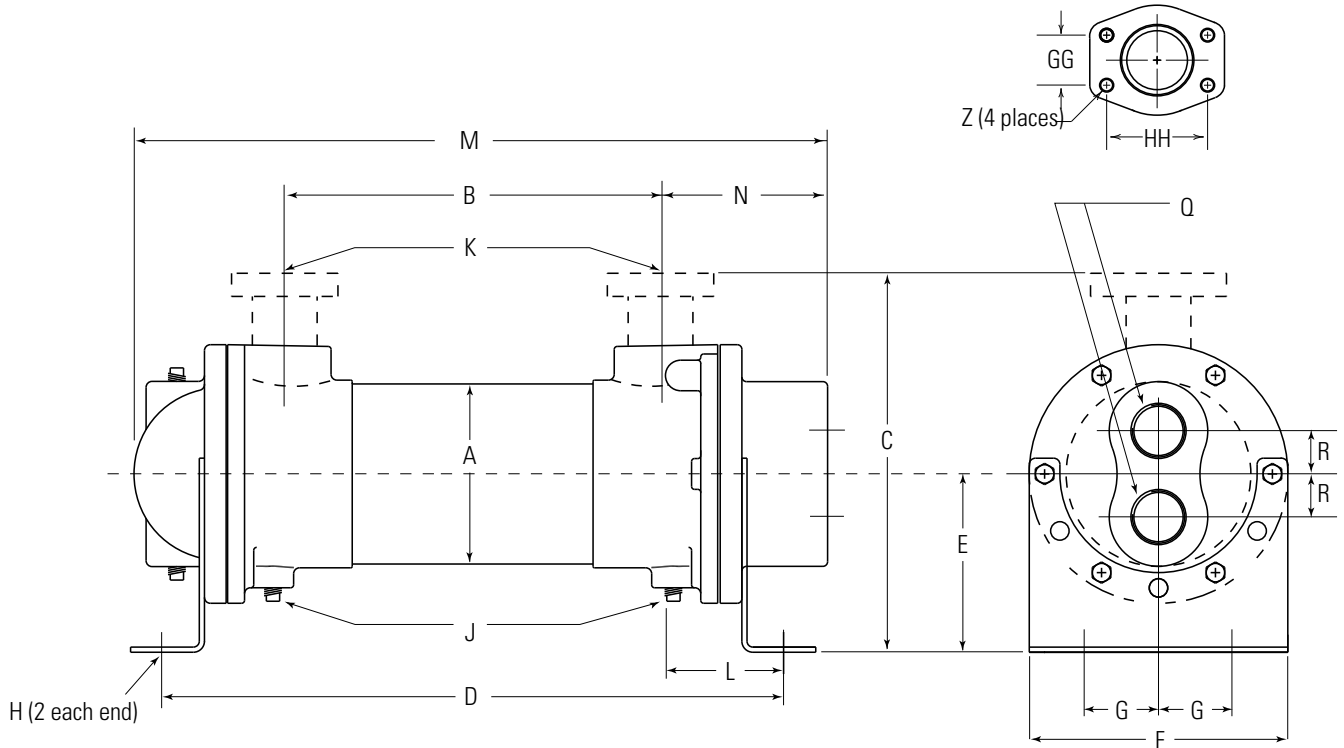

Flange Size	GG	HH	Z - CF	Z - CFM
1	1.03	2.06	3/8-16 UNC	M-10
1.50	1.41	2.75	1/2-13 UNC	M-12
2	1.69	3.06		
3	2.44	4.19	5/8-11 UNC	M-16

MODEL	A	B	C		D	E	F	G	H	J	K		L	M	N	P	Q	R
			NPT/BSPP SAE O-RING	SAE FLANGE							NPT/BSPP FLANGE	SAE O-RING						
B-701	3.656	7.00	6.25	C/F	12.01	3.62	5.25	1.50	.44 x 1.00	(2) .38	1.00	#16, 1 <sup>5</sup> / <sub>16</sub> -12 UNF-2B	2.69	13.28	3.30	(2) .38	1.00	.88
B-702		16.00			21.01									22.28				
B-703		25.00			30.01									31.28				
B-1002	5.125	15.50	7.38	8.46	21.71	4.00	6.75	2.00			1.50	#24, 1 <sup>7</sup> / <sub>8</sub> -12 UN-2B	3.06	23.29	3.80		1.50	1.19
B-1003		24.50			30.71									32.29				
B-1004		33.50			39.71									41.29				
B-1202		14.62			21.50									23.94				
B-1203	6.125	23.50	8.81	10.50	30.38	4.75	7.50	2.50	.44 x .88	(6) .38	2.00	#32, 2 <sup>1</sup> / <sub>2</sub> -12 UN-2B	3.44	32.81	4.56	(2) .50	2.00	1.44
B-1204		32.38			39.25									41.69				
B-1205		41.38			48.25									50.69				
B-1206		50.50			57.38									59.81				
B-1207		59.50			66.38									68.81				
B-1208		68.38			75.25									77.69				
B-1602		8.00			13.60									12.13				
B-1603	22.60		31.38	34.10														
B-1604	31.60		40.38	43.10														
B-1605	40.60		49.38	52.10														
B-1606	49.60		58.38	61.10														
B-1607	58.60		67.38	70.10														
B-1608	67.60		76.38	79.10														
B-1609	76.60		85.38	88.10														
B-1610	85.60		94.38	97.10														

NOTE: We reserve the right to make reasonable design changes without notice. Consult factory. All dimensions are inches.

# Dimensions

## Four Pass

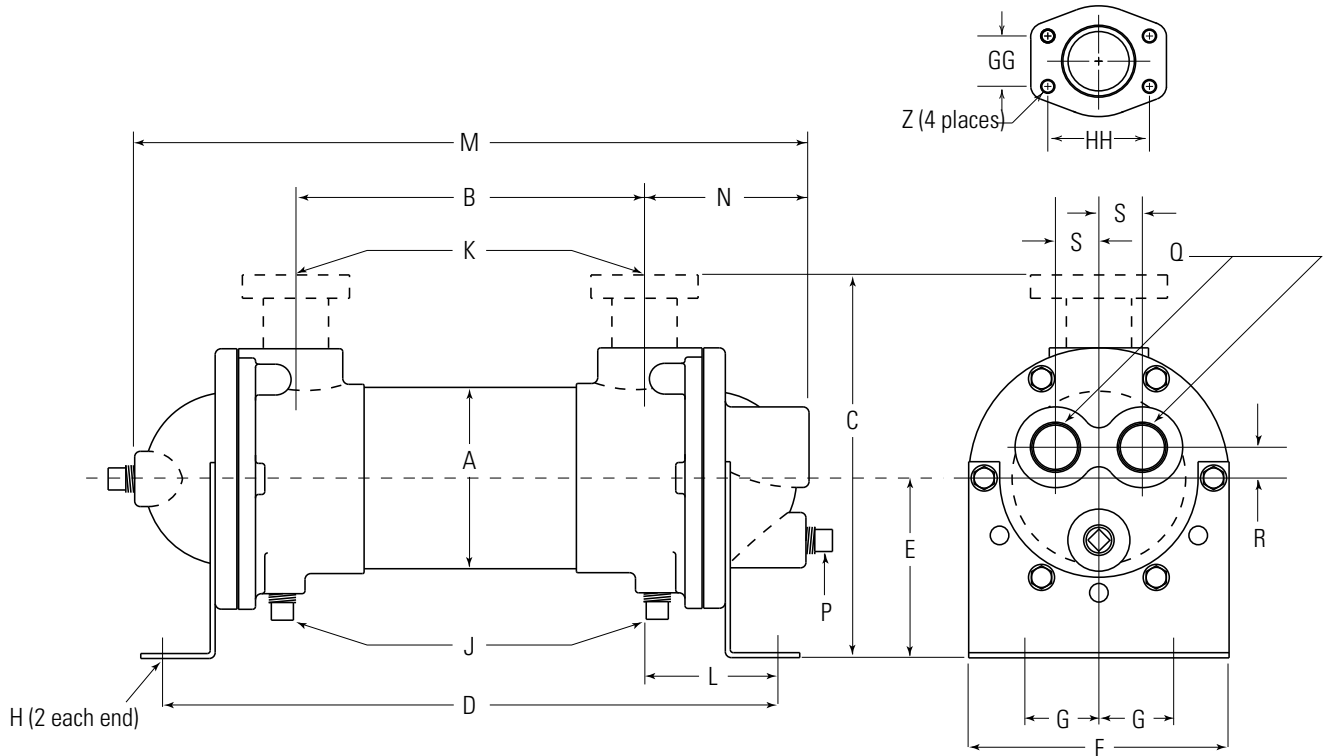

Flange Size	GG	HH	Z - CF	Z - CFM
1	1.03	2.06	3/8-16 UNC	M-10
1.50	1.41	2.75	1/2-13 UNC	M-12
2	1.69	3.06		
3	2.44	4.19	5/8-11 UNC	M-16

MODEL	A	B	C		D	E	F	G	H	J NPT	K		L	M	N	P NPT	Q NPT	R	S			
			NPT/BSPP SAE O-RING	SAE FLANGE							NPT/BSPP FLANGE	SAE O-RING										
B-701	3.656	7.00	6.25	C/F	12.01	3.62	5.25	1.50	.44 x 1.00	(2) .38	1.00	#16, 1 <sup>5</sup> / <sub>16</sub> -12 UNF-2B	2.69	13.57	3.32							
B-702		16.00			21.01									22.57						.75	.62	.88
B-703		25.00			30.01									31.57								
B-1002	5.125	15.50	7.38	8.46	21.71	4.00	6.75	2.00			1.50	1 <sup>7</sup> / <sub>8</sub> -12 UN-2B	3.06	23.57	4.12	(3) .38	1.00	.75	1.34			
B-1003		24.50			30.71									32.57						1.00	.75	1.34
B-1004		33.50			39.71									41.57								
B-1202	6.125	14.62	8.81	10.50	21.50	4.75	7.50	2.50	.44 x .88	(6) .38	2.00	#32, 2 <sup>1</sup> / <sub>2</sub> -12 UN-2B	3.44	24.44	4.90	(1) .50	1.50	1.06	1.40			
B-1203		23.50			30.38									33.31						1.50	1.06	1.40
B-1204		32.38			39.25									42.19								
B-1205		41.38			48.25									51.19						1.50	1.06	1.40
B-1206		50.50			57.38									60.31								
B-1207		59.50			66.38									69.31						1.50	1.06	1.40
B-1208		68.38			75.25									78.19								
B-1602		8.00			13.60									12.13						15.61	22.38	6.50
B-1603	22.60		31.38	35.72																		
B-1604	31.60		40.38	44.72																		
B-1605	40.60		49.38	53.72																		
B-1606	49.60		58.38	62.72																		
B-1607	58.60		67.38	71.72																		
B-1608	67.60		76.38	80.72																		
B-1609	76.60		85.38	89.72																		
B-1610	85.60		94.38	98.72																		

NOTE: We reserve the right to make reasonable design changes without notice. Consult factory. All dimensions are inches.

# Performance Curves

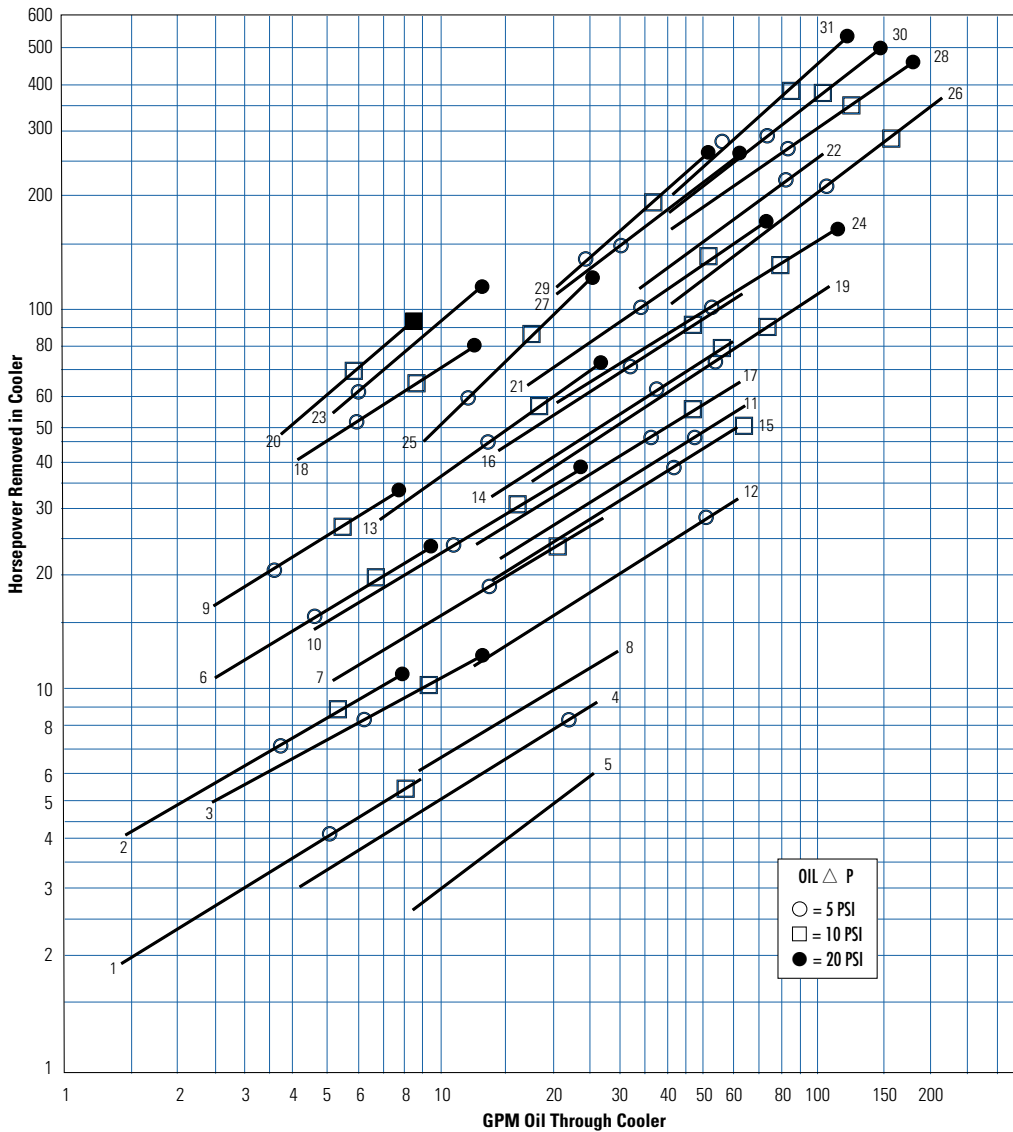

Model	Ship Wt. (lbs)
*1. B-401-A4-0	7
*2. B-402-A4-0	10
*3. B-701-A4-T	23
4. B-701-B6-F	23
5. B-701-C6-T	23
*6. B-702-A4-T	28
7. B-702-B4-F	28
8. B-702-C6-T	28
*9. B-703-A4-T	35
10. B-703-B4-F	35
11. B-1002-C4-T	49
12. B-1002-C6-T	49
13. B-1003-B4-F	65
14. B-1003-C4-T	65
15. B-1003-C6-T	65
16. B-1004-C4-T	72
17. B-1004-C6-T	72
*18. B-1202-A4-F	72
19. B-1202-C4-F	72
*20. B-1204-A4-F	110
21. B-1204-C4-F	110
*23. B-1602-A4-F	145
24. B-1602-C4-F	145
25. B-1604-B4-F	195
26. B-1604-D4-F	195
27. B-1606-C4-F	259
28. B-1606-D4-F	259
29. B-1608-C4-F	310
30. B-1608-D4-F	310
31. B-1610-D4-F	400

Shipping weights are approximate

WATER COOLED B

## Maximum Flow Rates

Example Model No.

**B - 1003 - C4 - F**

Unit Size	Shell Side (GPM)		Baffle Spacing		Tube Side (GPM)		
	A	B	C	D	O	T	F
400	9.6	—	—	—	25	—	—
700	17	29	29	—	61	31	15
1000	24	48	69	69	146	73	37
1200	29	57	115	115	224	112	56
1600	37	74	149	253	363	181	91

**Caution:** Incorrect installation can cause this product to fail prematurely, causing the shell side and tube side fluids to intermix.

## Piping Hook-up

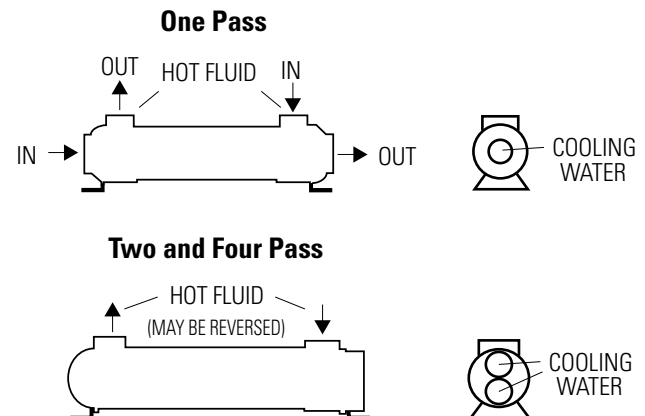

Specific applications may have different piping arrangements. Contact factory for assistance.

# Selection Procedure

Performance Curves are based on 100SSU oil leaving the cooler 40°F higher than the water temperature used for cooling. This is also referred to as a 40°F approach temperature. Curves are based on a 2:1 oil to water flow ratio. \*Curves are 1:1.

**Step 1 Determine the Heat Load.** This will vary with different systems, but typically coolers are sized to remove 25 to 50% of the input nameplate horsepower. (Example: 100 HP Power Unit x .33 = 33 HP Heat load.)  
If BTU/Hr. is known:  $HP = \frac{BTU/Hr}{2545}$

**Step 2 Determine Approach Temperature.** Desired oil leaving cooler °F – Water Inlet temp. °F = Actual Approach (Max. reservoir temp.)

**Step 3 Determine Curve Horsepower Heat Load.** Enter the information from above:  
Horsepower heat load x  $\frac{40}{\text{Actual Approach}}$  x Viscosity Correction A = Curve Horsepower

**Step 4 Enter curves** at oil flow through cooler and curve horsepower. Any curve above the intersecting point will work.

**Step 5 Determine Oil Pressure Drop from Curves:**  
○ = 5 PSI; □ = 10 PSI; ● = 20 PSI. Multiply pressure drop from curve by correction factor B found on oil viscosity correction curve.

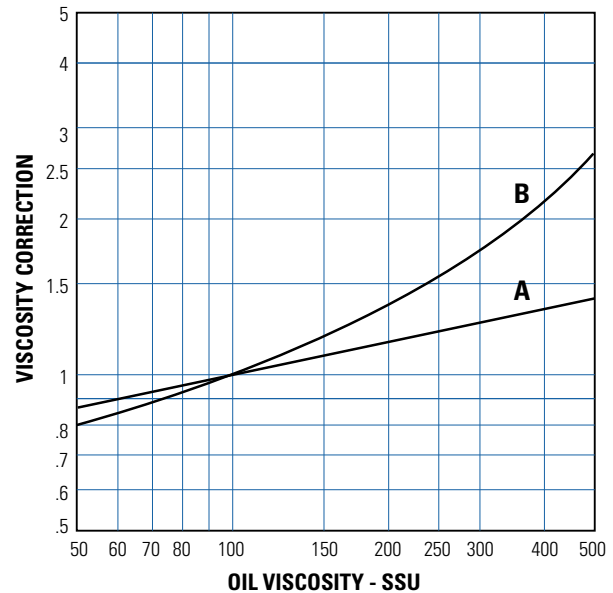

## Oil Temperature

Oil coolers can be selected using entering or leaving oil temperatures.

Typical operating temperature ranges are:

Hydraulic Oil	110°F - 130°F
Hydrostatic Drive Oil	130°F - 180°F
Bearing Lube Oil	120°F - 160°F
Lube Oil Circuits	110°F - 130°F

## Desired Reservoir Temperature

**Return Line Cooling:** Desired temperature is the oil temperature leaving the cooler. This will be the same temperature that will be found in the reservoir.

**Off-Line Recirculation Cooling Loop:** Desired temperature is the oil temperature *entering* the cooler. In this case, the oil temperature change must be determined so that the actual oil leaving temperature can be found. Calculate the oil temperature change (oil  $\Delta T$ ) with this formula:

$$\text{Oil } \Delta T = (\text{BTU's/Hr.}) / (\text{GPM Oil Flow} \times 210).$$

To calculate the oil leaving temperature from the cooler, use this formula:

$$\text{Oil Leaving Temp.} = \text{Oil Entering Temp} - \text{Oil } \Delta T.$$

This formula may also be used in any application where the only temperature available is the entering oil temperature.

**Oil Pressure Drop:** Most systems can tolerate a pressure drop through the heat exchanger of 20 to 30 PSI. Excessive pressure drop should be avoided. Care should be taken to limit pressure drop to 5 PSI or less for case drain applications where high back pressure may damage the pump shaft seals.