

FLUID COOLING | Mobile AOC Series

AIR COOLED AOC

Features

- Low AMP Draw Motors
- Remote Mount
- Does Not Block Main Engine Radiator
- Long Life Hydraulic Motor
- Heavy Duty Construction
- 3/4" Tube Size
- Heat Removal up to 160 HP
- Oil Flows to 150 GPM
- DC or Hydraulic Motors
- SAE Connections Standard
- High Performance Air Side Fin Design

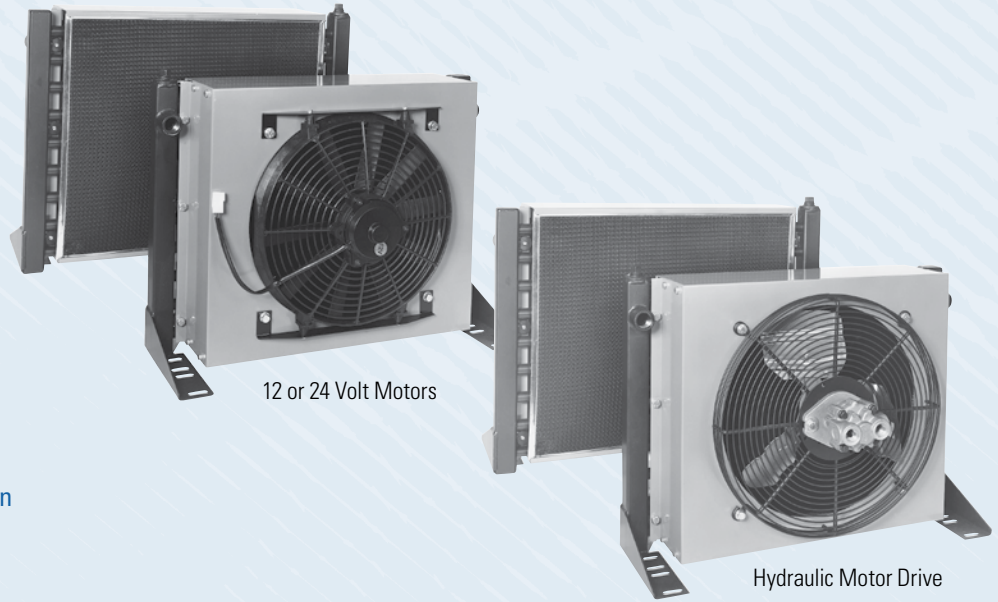

OPTIONS

Built-in Serviceable Bypass Valve
NPT or BSPP or SAE Connections

Ratings

Operating Pressure 300 psi
Test Pressure 300 psi
Operating Temperature 350° F

Materials

Tubes Copper
Fins Aluminum
Turbulators Aluminum
Fan Blade (DC Motor) High Impact Plastic
Fan Blade (Hydraulic motor) Aluminum with steel hub
Fan Guard (Hydraulic Motor) Steel with black baked enamel finish
Manifolds Steel
Connections Steel
Cabinet Steel with baked enamel finish
Filter Stainless frame with washable media
Nameplate Aluminum

Relief Bypass Valve Option

MODEL	DESCRIPTION
AOC-19 thru AOC-33	Available in either 30 psi or 60 psi settings. 3/4", external, all steel valve. May be removed for servicing.
AOC-37 thru AOC-70	Available in either 30 psi or 60 psi settings. 1-1/2", external, all steel valve. May be removed for servicing.

How to Order

AOC	-	[] []	-	[]	-	[]	-	[]
Model Series AOC - Standard		Model Size Selected		Connection Type* 1 - NPT 2 - SAE 3 - BSPP		Relief Bypass Blank - No Bypass 30 - 30 psi 60 - 60 psi		Specify Motor Required NM - No Motor 4A - 12 Volt 4B - 24 Volt 9 - Hydraulic Motor

*Other connection types available. Please consult factory for assistance.

Dimensions

AOC-19 thru AOC-33

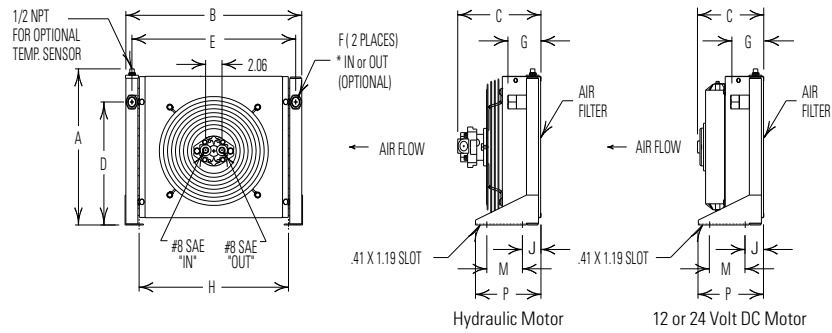

AOC-37 thru AOC-70

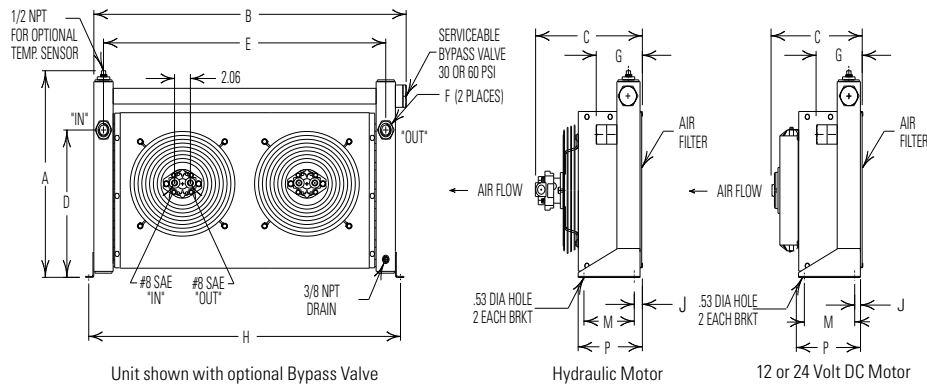

Model	A		B		C		D	E	F		G		H	J	M	P	Weight LBS.	HYD Motor CFM	12/24 V Motor CFM
	No Bypass	With Bypass	No Bypass	With Bypass	HYD Motor	DC Motor			SAE	NPT & BSPP	SAE	NPT & BSPP							
AOC-19	13.62	16.00	16.50	18.16	10.40	7.92	10.31	15.00	#12	.75	3.05	4.12	14.75	2.61	5.00	8.18	30	750	800
AOC-22	15.62	18.00	22.00	23.66			12.31	20.50					18.69				33	1150	1050
AOC-24	19.62	22.00	24.75	26.41	11.58	9.69	16.31	23.25					21.44				46	1900	1300
AOC-33	25.62	28.00	30.25	31.91	14.06	10.84	9.31	22.31	#16	1.00	4.34	26.97	1.06	6.50	8.31	65	2150	1500	
AOC-37	18.50	21.38	39.00	40.38			15.25	36.50								40.50	95	2150	1850
AOC-50	22.50	25.38	41.00	42.38	14.93	15.08	19.25	38.50	#20	1.25	4.62	5.97	42.50	1.12	8.37	120	3200	2300	
AOC-54	30.50	33.28	42.00	43.38			27.25	39.50					43.75			154	3800	2600	
AOC-57	36.50	39.38	48.00	49.38	17.79	24.62	32.75	45.50	#32	2.00	6.68	8.15	49.75	9.00	12.37	190	4200	2900	
AOC-70	38.38	41.25	51.00	52.38			34.00	48.50					52.75			1.62	12.12	304	7500

All dimensions in inches. We reserve the right to make reasonable design changes without notice. *Inlet and outlet oil ports reversible if relief bypass option is not used.

Specifications

Hydraulic motor data

Model	NUMBER OF FANS	MAXIMUM FAN SPEED	OIL FLOW REQUIRED PER FAN (GPM)	MINIMUM OPERATING PRESSURE (PSI)	MOTOR (IN ³ /REV) DISPLACEMENT
AOC - 19 thru AOC - 33	1	1725 RPM	1.6	300	.22
AOC - 37 thru AOC - 57	2				
AOC - 70	2		3.4	500	.45

Notes: Maximum pressure is 2000 PSI. Stated Minimum Operating Pressure is at Inlet Port of Motor. 1000 PSI Allowable Back Pressure.

12 and 24 volt DC motor data

Model	NUMBER OF FANS	FULL LOAD AMPS PER MOTOR		HORSEPOWER PER MOTOR	FAN SPEED	FAN DIAMETER (INCHES)
		12 VOLT	24 VOLT			
AOC - 19	1	12.5	6.3	1/5	1800 RPM	10
AOC - 22						12
AOC - 24, 33						14
AOC - 37	2	80	39	1	1800 RPM	12
AOC - 50, 54, 57						14
AOC - 70						20

Performance Curves

AOC - with DC Motor

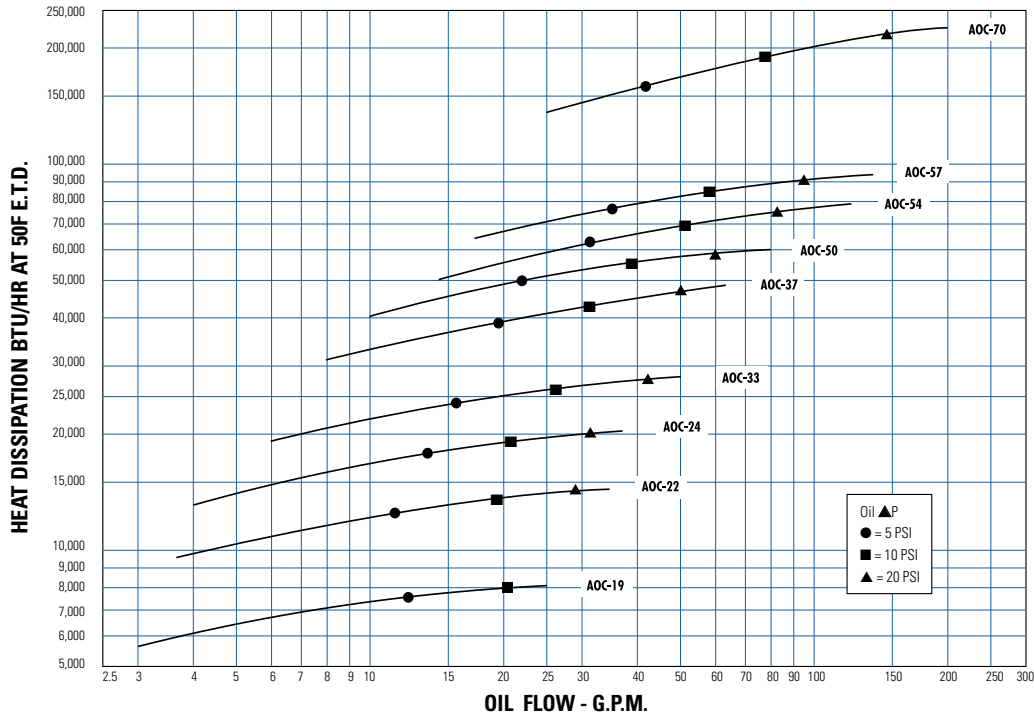

AOC - with Hydraulic Motor

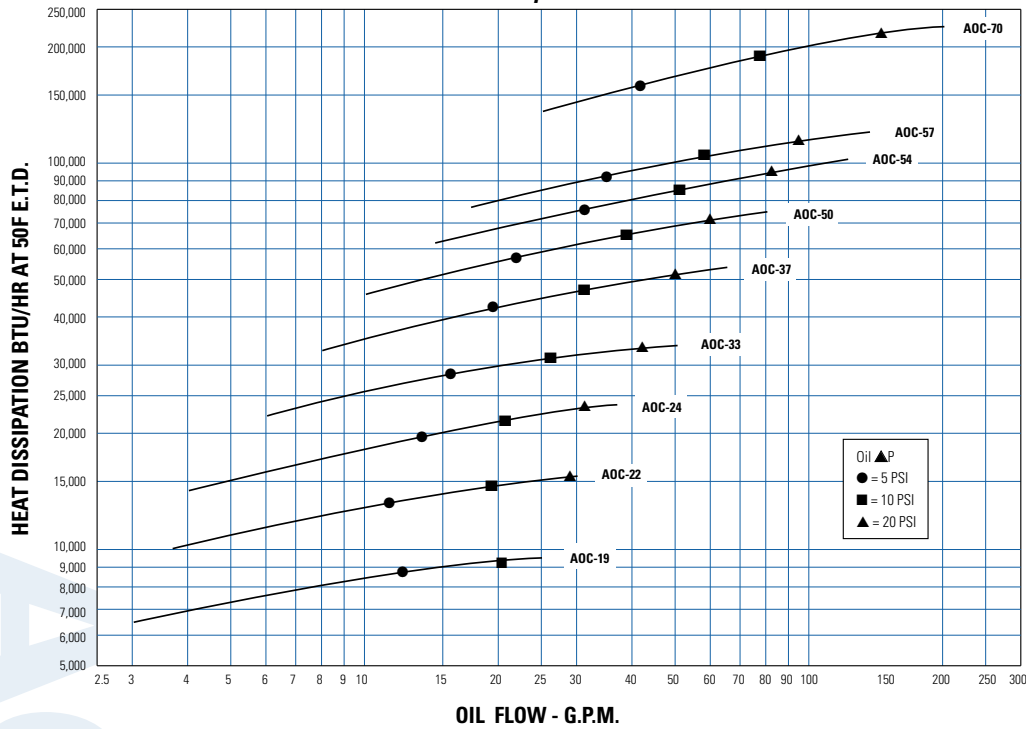

Selection Procedure

Performance Curves are based on 50SSU oil entering the cooler 50°F higher than the ambient air temperature used for cooling. This is also referred to as a 50°F Entering Temperature Difference (ETD).

STEP 1 Determine the Heat Load. This will vary with different systems, but typically coolers are sized to remove 25 to 50% of the input nameplate horsepower.

(Example: 100 HP Power Unit x .33 = 33 HP Heat load.)

To convert HP to BTU/Hr: HP x 2545 = BTU/Hr

STEP 2 Entering Temperature Difference. Desired oil entering cooler °F – Ambient air temp. °F = Actual ETD

STEP 3 Determine Curve BTU/Hr Heat Load. Enter the information from above:

$$\text{BTU/Hr heat load} \times \frac{50 \times C_v}{\text{ETD}} = \text{Curve BTU/Hr}$$

STEP 4 Enter curves at oil flow through cooler and curve horsepower. Any curve above the intersecting point will work.

STEP 5 Determine Oil Pressure Drop from Curves:

● = 5 PSI; ■ = 10 PSI; ▲ = 20 PSI. Multiply pressure drop from curve by correction factor found in oil ΔP correction curve.

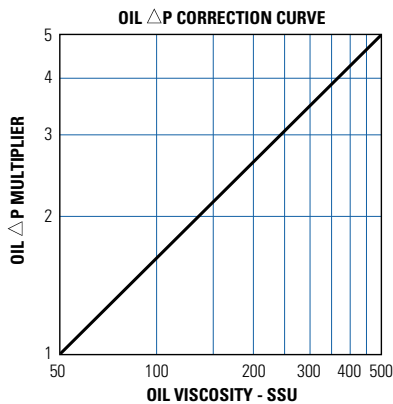

C_v Viscosity Correction

Average Oil Temp °F	OIL				
	SAE 5 110 SSU at 100°F 40 SSU at 210°F	SAE 10 150 SSU at 100°F 43 SSU at 210°F	SAE 20 275 SSU at 100°F 50 SSU at 210°F	SAE 30 500 SSU at 100°F 65 SSU at 210°F	SAE 40 750 SSU at 100°F 75 SSU at 210°F
100	1.14	1.22	1.35	1.58	1.77
150	1.01	1.05	1.11	1.21	1.31
200	.99	1.00	1.01	1.08	1.10
250	.95	.98	.99	1.00	1.00

Desired Reservoir Temperature

Return Line Cooling: Desired temperature is the oil temperature leaving the cooler. This will be the same temperature that will be found in the reservoir.

Off-Line Recirculation Cooling Loop: Desired temperature is the oil temperature entering the cooler. In this case, the oil temperature change must be determined so that the actual oil leaving temperature can be found. Calculate the oil temperature change (oil ΔT) with this formula:
Oil $\Delta T = (\text{BTU's/Hr.}) / (\text{GPM Oil Flow} \times 210)$.

To calculate the oil leaving temperature from the cooler, use this formula:
Oil Leaving Temp. = Oil Entering Temp – Oil ΔT .

This formula may also be used in any application where the only temperature available is the entering oil temperature.

Oil Pressure Drop: Most systems can tolerate a pressure drop through the heat exchanger of 20 to 30 PSI. Excessive pressure drop should be avoided. Care should be taken to limit pressure drop to 5 PSI or less for case drain applications where high back pressure may damage the pump shaft seals.

Oil Temperature

Typical operating temperature ranges are:

Hydraulic Motor Oil	110° - 130°F
Hydrostatic Drive Oil	130° - 180°F
Bearing Lube Oil	120° - 160°F
Lube Oil Circuits	110° - 130°F